

INSTRUCTION MANUAL

RL-WO8014S-U

ONE PIECE WC SUITE, S-TRAP C/W MOUNTING
SCREW & FLUSHING MECHANISM, U-SLOT

RL-WO8014P-U

ONE PIECE WC SUITE, P-TRAP C/W MOUNTING
SCREW & FLUSHING MECHANISM, U-SLOT



IMPORTANT SAFETY INFORMATION

The instructions contained herein are for the safe and correct use, care and maintenance of the product, to minimize the risk of injury and damage to yourself, other persons, or property.

Please read the following safety information thoroughly and retain this document for future use and reference.



WARNING

Instructions accompanied by this symbol could lead to death or serious injury if they are ignored or followed improperly.

IMPORTANT SAFETY, INSTALLATION AND OPERATING INSTRUCTIONS

Please read this manual and ensure that you understand the instructions and procedures stated within before installing or operating the product.

Rigel products have been designed and tested to be safe and risk-free when installed, operated and maintained in good working order, in accordance with the instructions and recommendations found in this document.

There are no user-serviceable parts in this product. Please contact a qualified and licensed trades person should the product require dismantling and/or repairs.

Supervision should be given to any persons who may have difficulty understanding or operating the controls of the product. Extra consideration should be given to the young, infirm, elderly, or any person inexperienced in the correct operation of the product's controls.

DISCLAIMER

While every effort has been made to ensure that the information contained within this document was accurate and complete at the time of printing, Rigel Technology (S) Pte Ltd shall not be held responsible for any errors, omissions or inaccuracies. By installing or using the product, the user agrees that no responsibility for the consequences resulting from any misinformation shall be incurred on Rigel Technology (S) Pte Ltd. Rigel Technology (S) Pte Ltd reserves the right to change the specifications and functions of the product described herein at any time without prior notice.

No part of this guide may be reproduced, stored in a retrieval system, or transmitted, in any form or by any means, electronic, mechanical, recording, or otherwise, without the prior written permission of Rigel Technology (S) Pte Ltd.

GENERAL SPECIFICATIONS

DIMENSION	745 x 415 x 800	
ROUGH-IN TRAP DISTANCE	P = 185mm S = 150mm - 305mm	
MIN WATER PRESSURE	100kPa (FLOWING)	
DISCHARGE VOLUME	RL-WO8014S-U	FULL FLUSH 6.0L / REDUCED FLUSH 3.0L
	RL-WO8014P-U	FULL FLUSH 6.0L / REDUCED FLUSH 3.0L
SEAT & COVER	FT-SC0101PS	

RL-WO8014S-U (S-TRAP-U)

NO.	PART NO.	DESCRIPTION	QTY
①	RL-WO8014S-U	ONE PIECE WC SUITE, F-TRAP,U SLOT	1
②	FT-SC0101PS	SEAT & COVER, PP SOFT-CLOSING	1
③	FT-SCWF80MM-S	FLOOR MOUNTING SCREW, LENGTH 80MM,SIDE	SET
④	FT-PCPS-VT103	PAN COLLAR, BEND VT103, VERTU	1
⑤	-	3 INCHES FLUSHING MECHANISM SET	1

RL-WO8014P-U (P-TRAP-U)

NO.	PART NO.	DESCRIPTION	QTY
①	RL-WO8014P-U	ONE PIECE WC SUITE, F-TRAP,U SLOT	1
②	FT-SC0101PS	SEAT & COVER, PP SOFT-CLOSING	1
③	FT-SCWF80MM-S	FLOOR MOUNTING SCREW, LENGTH 80MM,SIDE	SET
④	FT-PCP-F102	PAN COLLAR, STRAIGHT P, F102	1
⑤	-	3 INCHES FLUSHING MECHANISM SET	1

PART LIST ILLUSTRATION

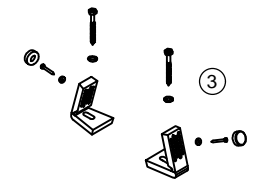
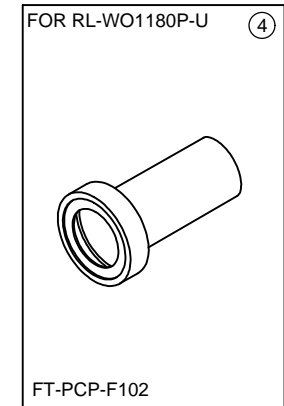
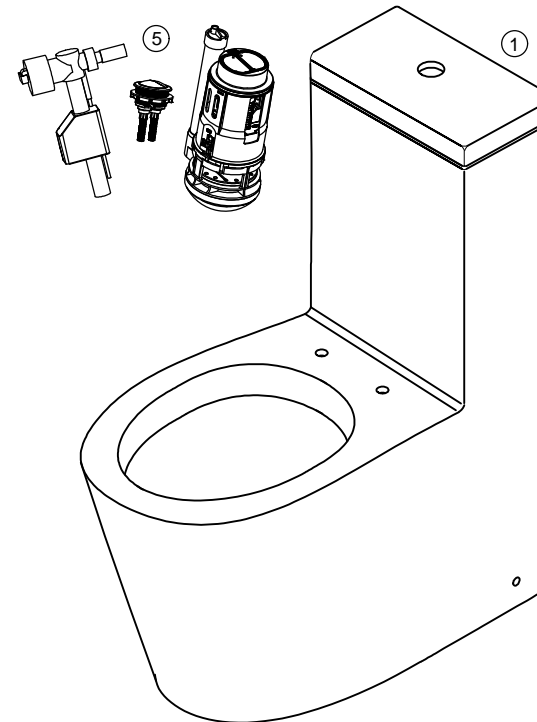
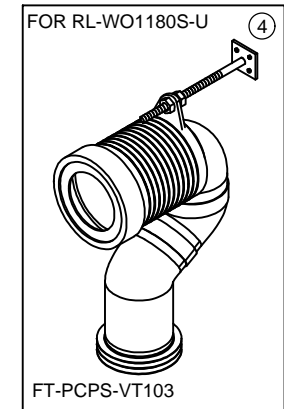
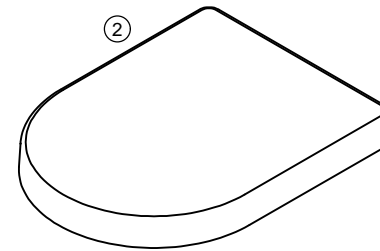

INSTALLATION GUIDE

Please read carefully the following notice of usage instructions before use, to make sure for correct use.
(Practice use based on actually sample.)

For your safety and keep all parts use in best state, please abide by the following instructions.

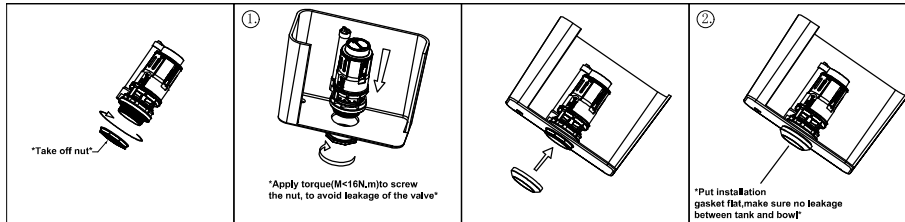

Installation push button with tank cover

I Installation the push button with tank cover.

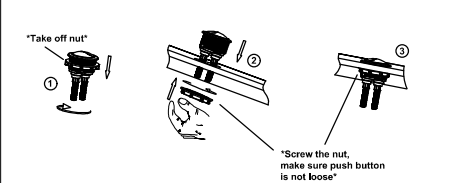

II Adjustment of the push rod.

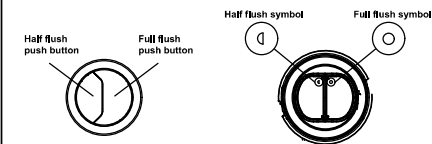

II Adjustment of the push rod.

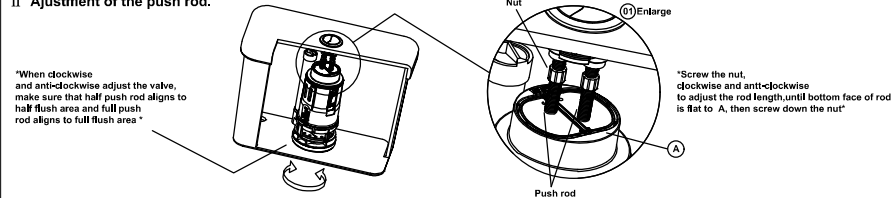

Refill tube installation

NOTE: refill tube optional based on customer's requirement.

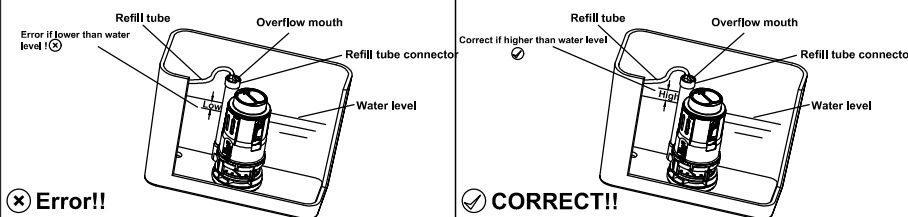

INSTRUCTION:
1, Please read carefully the following installation instructions. In order to avoid injuring body or damaging equipment, please install the equipment following the instructions step by step.
2, The instructions are compiled according to the up-to-date product information. We reserve the rights to make the change about specifications, packaging and supplying without prior notice.
3, When valve installed, the critical level mark on fill valve (identified by a C.L. mark on valve body) should be at least 1" (=25.4mm) above top of overflow pipe. This is a plumbing code.
4, We shall not be responsible for any failure of using any parts from other companies.
5, Water temperature: 2°C-45°C.
6, Water pressure: 0.02Mpa-0.8Mpa.



No bleach drop in

WARNING

DO NOT USE OR DROP ANY CHLORINE OR ANY CHEMICAL RELATED COMPONENTS. USE OF SUCH PRODUCTS WILL (1) RESULT IN DAMAGE TO TANK COMPONENTS AND MAY CAUSE FLOODING AND PROPERTY DAMAGE AND (2) VOID WARRANTY. DO NOT OVERTIGHTEN NUTS, OR TANK/BOWL MAY CRACK.

INSTALLATION GUIDE

Adjustment of water flow

I Adjustment of full flush volume:

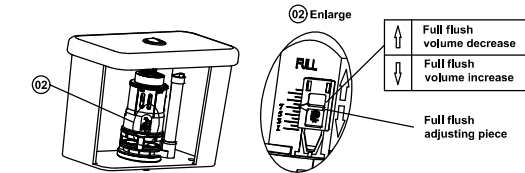

II Adjustment of half flush volume:

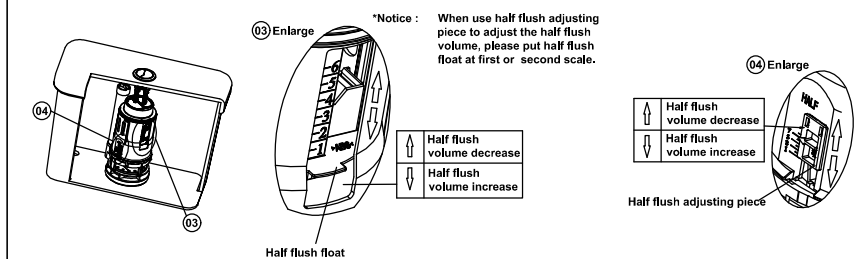

Exclusive ways of normal problem

No flush or flush volume is too little when is depressed the push button.

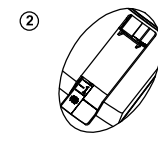
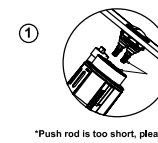

Full flush water level and half flush water level are too high or too low.

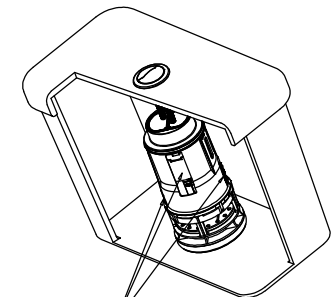

"Half flush float, half flush adjusting piece and full flush adjusting piece don't adjust well, please re-adjust."

Leakage of flush valve

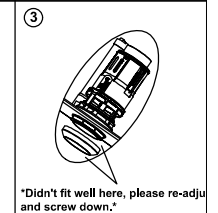
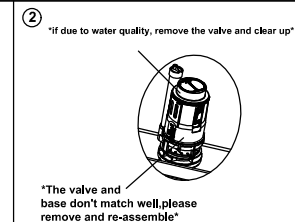
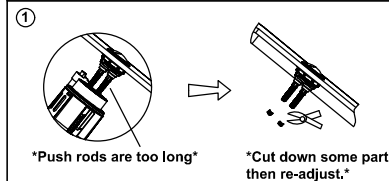

INSTALLATION GUIDE FOR S-Trap-U

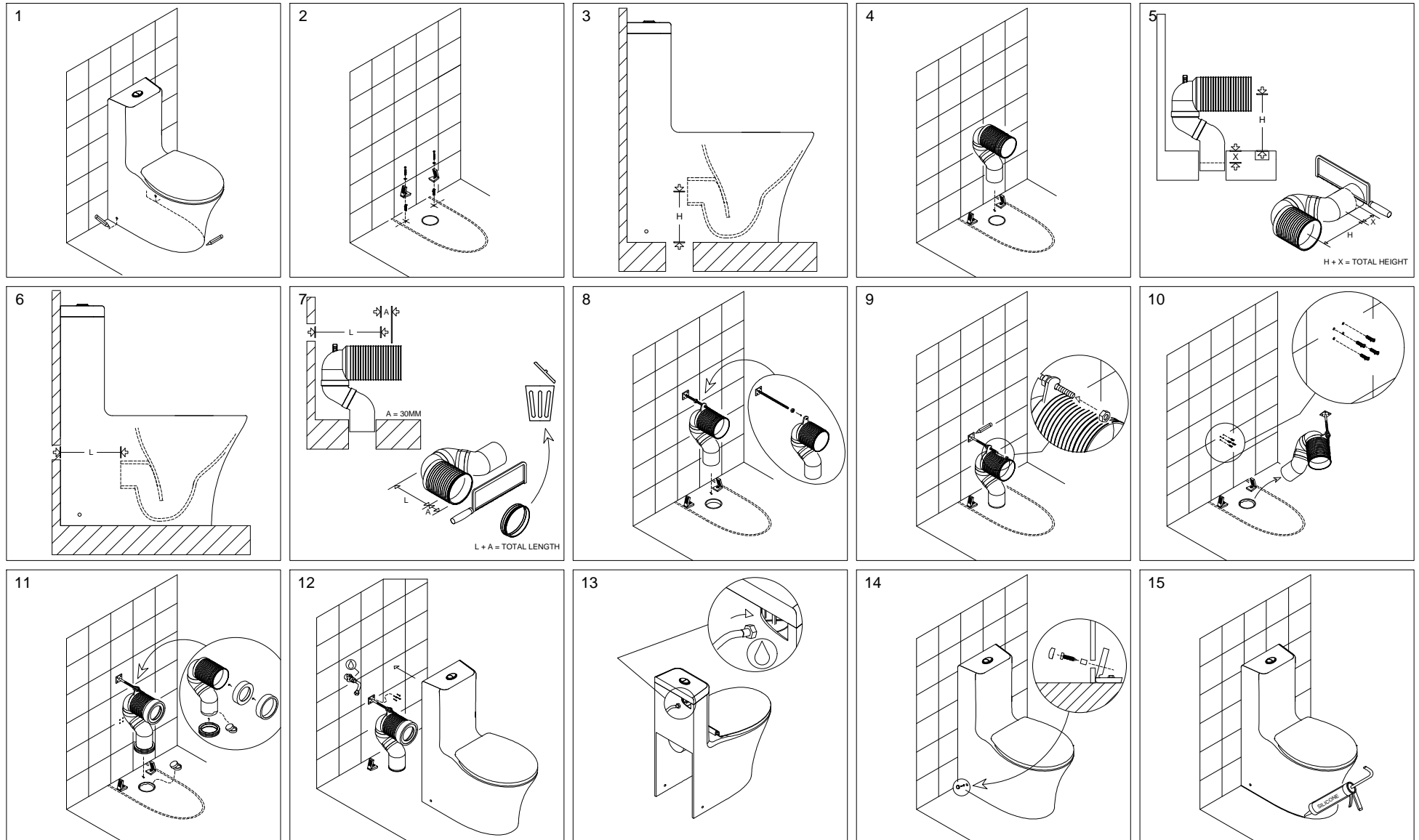

INSTALLATION GUIDE FOR P-Trap-U

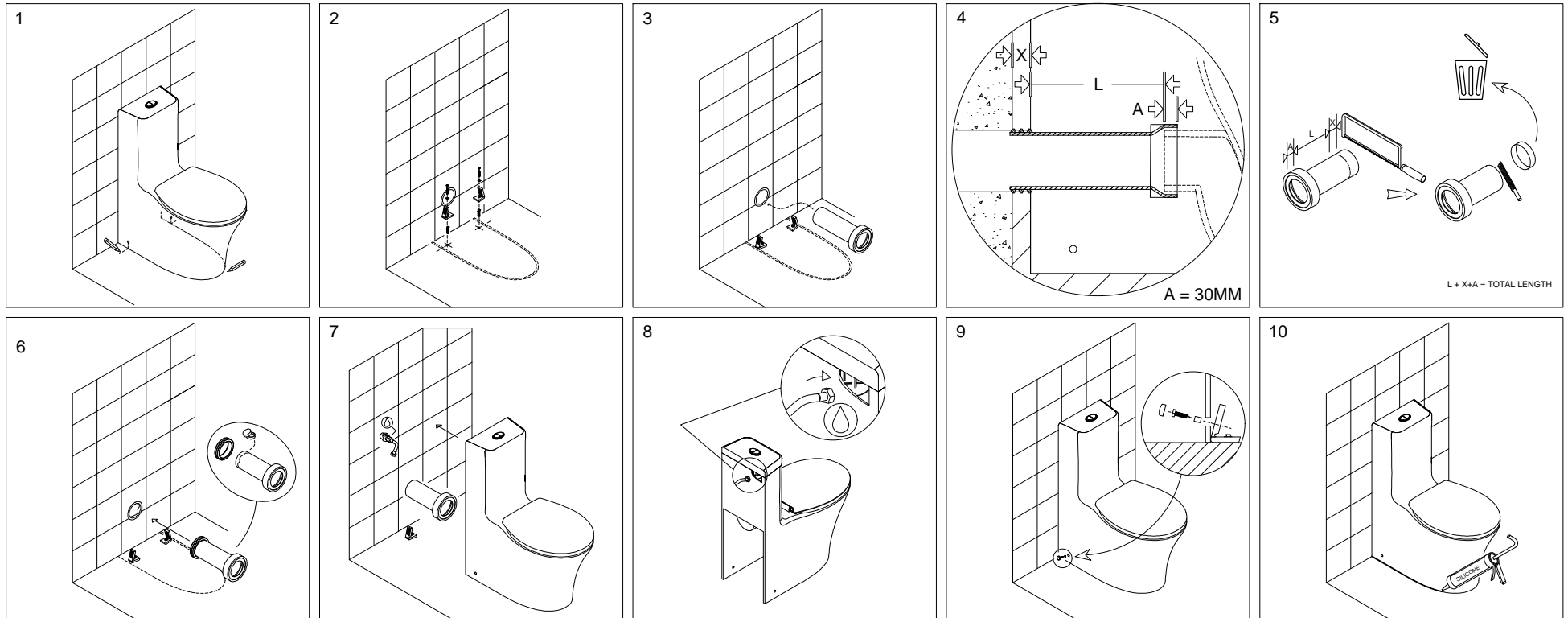

PRODUCT DIMENSION

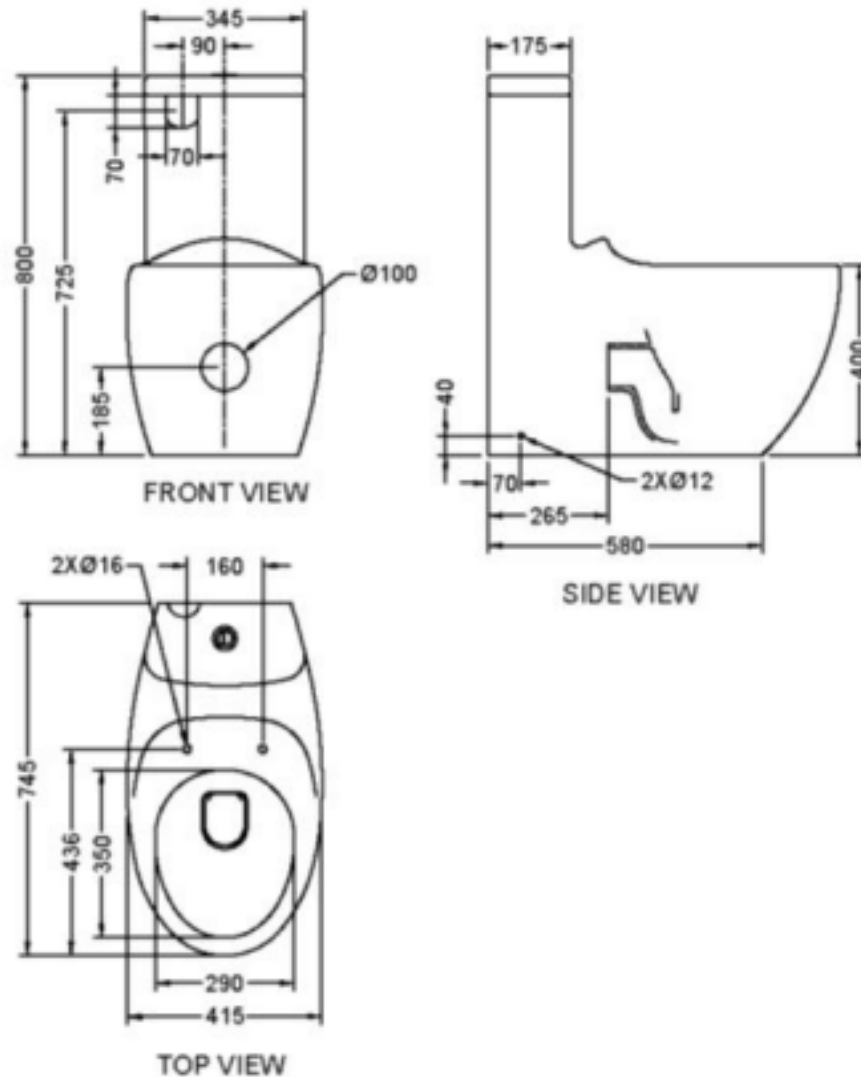

INSTALLATION DIAGRAM

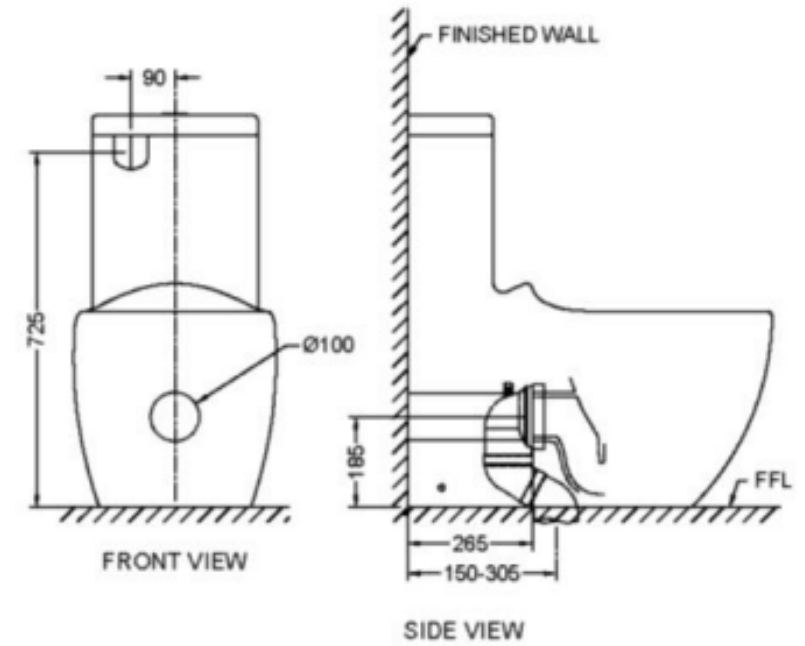

All dimension in mm.

PRODUCT CARE & CLEANING GUIDE

The instructions contained herein are for the proper care and maintenance of the product, to ensure optimal function.

Please read the following care and cleaning information thoroughly and retain this document for future use and reference.

CARE AND CLEANING INSTRUCTIONS

Before commencing on the cleaning of your Rigel product with any cleaning agents, please read the directions on the cleaning agent to ensure that it is safe for use with the materials on your Rigel product.

Always test any new cleaning agents on a small, inconspicuous spot on your Rigel product before applying it on the entire surface.

Clean the product regularly with a soft material (e.g. sponge) dipped in a mild, non-abrasive detergent to avoid scratches or corrosion.

Avoid prolonged exposure to the sun and contact with corrosive chemical solvents.

Do not use hard objects to pound on the product as this may damage or scratch the surface.

Situation	Recommended Cleaning Agents	Instructions
Routine cleaning	<ul style="list-style-type: none"> - Soap - Mild detergent - Warm water 	Sponge along the polish lines and rinse with clean water. Wipe dry.
Fingerprint stains	<ul style="list-style-type: none"> - Soap - Warm water - Organic solvents (e.g. acetone, alcohol, methylated spirits) 	Sponge the stains following the polish lines and rinse with clean water. Wipe dry.
Stubborn stains or discolouration	<ul style="list-style-type: none"> - Mild abrasive cleaning products - Specialty stainless steel cleaning products 	Use a rag, sponge or soft brush to apply the cleaning agent, rubbing or brushing along the polish lines. Rinse well with clean water and wipe dry.

NOTE : Avoid the use of harsh chemicals and/or abrasive materials to clean your Rigel product as they may void your warranty.

TROUBLE SHOOTING GUIDE

OUT-OF-BOX FAILURE

If the product does not function as specified or reasonably expected upon first use after installation, please contact your contractor or trades person to check if the installation and commissioning are performed satisfactorily and in accordance with the instructions in the Installation Manual. You or your installer may contact Rigel for any advise and we will be glad to be of assistance.

Should this still not resolve the issue, please contact our Customer Support Department and we will arrange for a visit by a Rigel service technician if necessary.

PERFORMANCE DECLINE

If the product is exhibiting a noticeable decline in performance after substantial use, please refer to the Product Care and Cleaning section of this Manual to check if simple home maintenance is required.

Should product performance not improve after simple home maintenance is performed as per the instructions in the Product Care and Cleaning section, please contact our Customer Support Department to discuss the issue you are facing, and to request for service under warranty if applicable.

RIGEL TECHNOLOGY (S) PTE LTD (HQ)

RIGEL INNOVATION CENTRE

20 Changi Business Park Central 2 Singapore 486031

CUSTOMER SUPPORT DEPARTMENT

Tel: (65) 6812 6288 Fax: (65) 6812 6388

Office Working Hours: 8:30am - 6.00pm (Monday to Thursday)

8:30am - 5.30pm (Friday)

E-mail: service@rigel.com.sg

WARRANTY

Please read the following warranty information thoroughly and retain this document for future use and reference.

Rigel Technology (S) Pte Ltd ("Rigel") warrants the products against any defect of materials or workmanship for a period of 1 year from the date of purchase.

Within the warranty period, all defective parts will be repaired and/or replaced free of charge.

To be eligible for free repair and/or replacement, any service work on the product must be undertaken by Rigel or our approved agents.

Service under this warranty will not affect the warranty expiry date, and any warranty on exchanged parts or products will end when the warranty expires.

This warranty is only applicable for products properly installed and operated in accordance to the operating procedures stated in the instruction manual.

This warranty does not extend to washroom accessories or other peripheral items.

Rigel's responsibility under this warranty does not apply to damage/defects caused by:

- Misuse, negligence, or accidents.
- Public abuse or vandalism.
- Repairs or alterations not authorized by or performed without consultation from Rigel.
- Repairs or alterations that do not comply with Rigel's installation instruction.
- Repairs or alterations that were not performed with genuine parts supplied by Rigel.

Rigel will not be held liable for any incidental or consequential damages, including loss of profits or savings, arising from the use or misuse of the products.

The terms in this warranty are only valid after:

- Full payment has been made.
- The official Warranty Card is completely and correctly filled out in ink and returned to Rigel within 14 days of purchase. Loss or misplacement of the Warranty Card, or unauthorized amendments to the Warranty Card, shall render the warranty null and void.

This warranty is in addition to your statutory and other legal rights.

CUSTOMER SUPPORT

AFTER SALES SERVICE

Rigel's Customer Support Team can provide you with service visits, sale of spare parts, and general product help and advise.

SPARE PARTS

Spare parts for all Rigel products are available for up to 10 years after the product's date of final manufacture. You should only purchase spare parts directly from our Customer Support Department, or from Rigel's approved stockists or merchants to ensure authenticity and to maintain validity of your warranty.

NOTE: As a safety precaution, spare parts that require exposure to voltage from the power grid mains will only be send to qualified personnel.

SERVICE GUARANTEE

All servicing provided by Rigel will be performed by a trained technician or agent, with genuine spare parts, and will come with a 6-month warranty on the repair. Servicing outside of the product's warranty will be charged at a reasonable cost.

CONTACT US

RIGEL TECHNOLOGY (S) PTE LTD

RIGEL INNOVATION CENTRE (HEADQUARTER & SHOWROOM)

20 Changi Business Park Central 2 Singapore 486031

Tel: (65) 6812 6288 Fax: (65) 6812 6388

Office Working Hours : 8:30am - 6.00pm (Monday to Thursday)

8:30am - 5.30pm (Friday)

E-mail: sales@rigel.com.sg

Website: www.rigel.com.sg

RIGEL TECHNOLOGY (M) SDN BHD

Wisma Rigel, 16 & 18, Jalan 3 / 33B, MWE Commercial Park, 6 1/2 Miles, Off Jalan Kepong, 52000

Kuala Lumpur, Malaysia

Tel: (603) 6258 6016 Fax: (603) 6258 5498

Office Working Hours: 8:30am - 6.00pm (Monday to Friday)

E-mail: sales@rigel.com.my

Website: www.rigel.com.my

RIGEL TECHNOLOGY (NINGBO) CO. LTD

No 6, Chuangye Road, West Of Bonded Zone, Beilun, Ningbo, Zhejiang, China

Tel: (86) 574 5626 1688 Fax: (86) 574 5626 1588

RIGEL TECHNOLOGY CERAMICS (SICHUAN) CO. LTD

Shuanghechang. Anfu Town, Naxi District, 646300 Luzhou City, Sichuan, China

Tel: (86) 830 4270 155 Fax: (86) 830 4270 636